

Transient Model of a Doubly Excited Reluctance Motor

L. Xu, Student Member, IEEE F. Liang Non-Member, T.A. Lipo Fellow, IEEE
 University of Wisconsin-Madison
 Dept. of Electrical and Computer Engineering
 1415 Johnson Drive
 Madison, WI 53706

Abstract - A transient machine model of a doubly fed reluctance motor is derived by means of winding function and d-q transformation theory. The machine consists of a double wound stator having four and eight pole sets. The rotor is equipped with six poles. The machine, related to the Hunt motor, has a synchronous speed of a twelve pole machine. Comparison of simulated to tested results indicates that the higher harmonics in the motor inductances are important for predicting current waveform.

KEYWORDS: Reluctance Motor, Hunt Motor, Electric Machine Modelling.

Introduction

The cascade connection of an induction machine has long been known as a desirable means of obtaining low speed operation. In general, such machines employ two separate windings on the stator of a different pole number. One of the stator windings acts as the normal excited stator winding while the other acts an equivalent rotor winding which is typically short circuited. The rotor is equipped with a complicated winding which couples the p pole and the q pole fields set up by the two stator windings. In the early 1900's there were several attempts to develop a winding which simultaneously performs the function of both stator or rotor windings. The most notable are the work of Hunt and Creedy [1,2]. The Hunt motor became widely known for its suitability for arduous low speed duty. High starting torques and speed regulation were obtained by resistance control without the need for slip rings.

The Hunt motor was proposed, with some success, by Kusko and Somuah [3] for use as a doubly fed induction motor drive. In this case, the second stator winding was used to pump back energy to the supply by means of a frequency converter. The machine suffered from the point of view of efficiency, however, due to the rotor copper losses which must now be added to the usual induction motor copper losses represented by the losses in the two stator windings.

The so-called self-cascaded machines of Hunt were investigated thoroughly by Broadway [4,5] who proposed a salient rotor having a simple unwound reluctance type structure in place of the complicated wound rotor of Hunt [6-8]. This machine is capable of operation either as an induction machine or a synchronous machine by suitable excitation of a second set of taps on the machine. Figure 1 depicts the stator and rotor of the induction machine version proposed by Broadway. The stator consists of a single winding with three parallel paths per phase. In this case the winding would set up a pole pair number of a multiple of three with respect to main

terminals A,B and C and a nontriple pole pair number with respect to the star points, a,b, and c. The rotor winding consists of a number of saliencies equal to half the sum of the pole number of the two stator fields. This machine is particularly desirable for a variable speed drive since the power can be taken from terminals at slip frequency and fed back to the supply by means of a frequency converter as illustrated in Fig. 1. In general, since machines of low pole number and therefore high speed are desirable for good power density, such a machine takes the form of a stator winding having a two pole/six pole construction with the corresponding rotor having four poles.

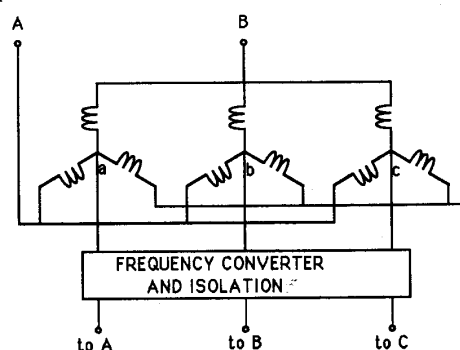

Fig. 1 $2(p+q)$ Pole Stator Winding with Three Parallel Paths.

Figure 2 shows the winding diagram of a synchronous machine version of this machine. In this case only two parallel paths per phase are used with respect to the main terminals resulting in an even pole pair number p with respect to A,B and C and pole pair half this number q with respect to the star points. The device can be operated as a synchronous machine by applying a dc voltage between the star points as shown in Fig. 2.

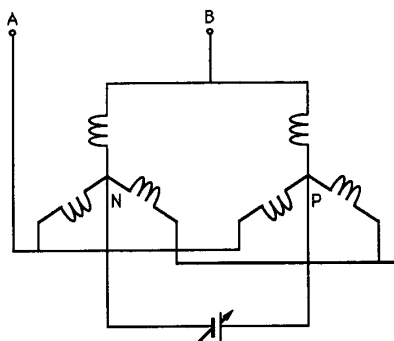

Fig. 2 $2(p+q)$ Pole Stator Winding with Two Parallel Paths.

90 CH 272-5 BC A paper recommended and approved by the IEEE Electric Machinery Committee of the IEEE Power Engineering Society for presentation at the IEEE/PES 1990 Summer Meeting, Minneapolis, Minnesota, July 15-19, 1990. Manuscript submitted September 5, 1989; made available for printing April 3, 1990.

Recently, the synchronous machine version of the Broadway concept was proposed as a high efficiency machine by Heyne and El-Antably [9]. Termed the Doubly Excited Reluctance Motor (DERM), this machine has a sine wave efficiency reaching 0.95 when measured on a machine rated at 15 HP. Such an efficiency is substantially greater than for conventional induction machines of the same rating which average 86% for standard squirrel cage machines and 90% for high efficiency designs according to NEMA standards. Operation of this machine was also investigated experimentally when supplied from a six-step voltage source inverter. The stator of this machine is equipped with two sets of sinusoidally distributed windings with the number of poles p and q being eight and four respectively. The rotor of the machine is a six-pole design and consists of axially laminated segments constructed without an explicit damper winding in the manner of Russell and Norsworthy[10]. The eight-pole winding is excited from a three phase AC supply while four-pole winding is excited from a DC supply. The machine operates with a synchronous speed dictated by the frequency applied to the eight pole winding together and twice the number of rotor poles (i.e. 600 RPM for a 60 Hz supply). Since the DERM has no rotor windings its terminal characteristics are that of a synchronous machine but with no brushes or slip rings. Also, since the excitation current is carried in the stator windings themselves, auxiliary means of excitation such as a rotating exciter with rotating diodes can be dispensed with, making the machine very attractive as a replacement for an induction motor in relatively low speed applications not requiring a severe starting duty.

Thus far, little attention has been focused on the transient analysis of such machines. In most cases, derivation of the motor models have been semi-intuitive with modifications of the conventional induction and synchronous machine made to incorporate the different pole numbers. While steady state correlation has been obtained with phasor analysis, little attention has been paid to the transient behavior of the machine, for example starting performance. To the end, a scheme for modelling and simulation of the synchronous version of the doubly excited reluctance machine is clearly necessary. In this paper, a complete development of a suitable $d-q$ model is developed based on $d-q$ transformation theory. The approach highlights the coupling that exists between the two stator windings and clearly demonstrates why the machine operates as an effective $2(p+q)$ machine. Hence, the analysis is also important to the understanding of the principle of operation of this machine which heretofore relied upon intuitive arguments.

The Stator and Rotor Structure

The stator configuration of the DERM machine [9] has conventional laminations with 36 uniformly distributed semi-open slots. A schematic of the connection diagram and a pictorial representation of the poles established by the rotor and two stator windings is shown in Figs. 3 and 4 respectively. When viewed from one set of leads, the winding has a three phase, double-star connected, 8-pole construction. When viewed from the other terminals, however, the winding is single phase, with four poles. When these two sets of leads are powered simultaneously from two independent sources, the terminal currents will not affect each other due to the symmetric nature of the winding. Therefore, in this paper, superposition will be used and it will be assumed that the stator winding of the DERM can be replaced by two equivalent, physically separated windings while the currents remain unchanged. Hence, iron saturation effects are neglected in this analysis. The rotor of the machine is divided into six segments and each segment consists of a stack of axially laminated iron sheets sandwiched with nonmagnetic materials. The rotor lamination consists of grain-oriented iron which has the maximum permeance along the direction of the lamination plane.

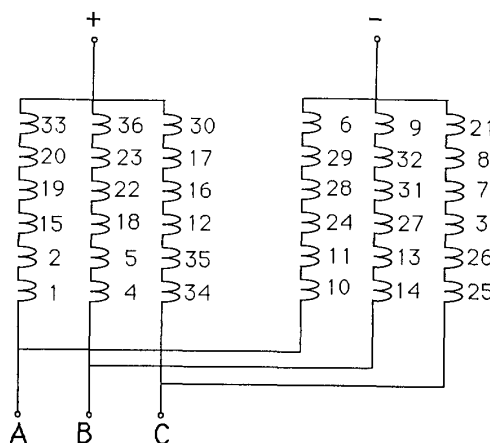

Fig. 3 Winding Distribution and Connection Diagram for Doubly Excited Reluctance Machine.

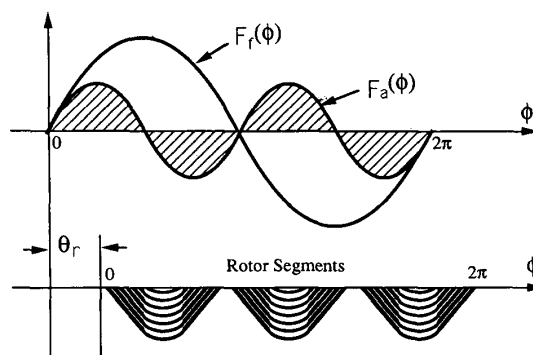

Fig. 4 Pictorial Representation of the 8 pole/4 pole stator and 6 Pole Axially Laminated Rotor.

Computation of Inductance as a Function of Rotor Position

Calculation of machine inductances can be calculated by a variety of means including field theory, finite elements and various circuit approaches. A particular convenient approach is called the method of winding functions in which the inductances of the machine are calculated by an integral expression representing the placement of winding turns along the air gap periphery. The method is particularly convenient for the analysis of unusual machines since it assumes no symmetry in the placement of any motor coil in the slots. As is the case with most inductance calculations it is assumed that:

- 1). The iron of the rotor and stator has infinite permeability and saturation is not considered;
- 2). The stator surface is considered smooth and the effects of slots are corrected by the Carter coefficient.

According to winding function theory [11,12], the mutual inductance between any two windings "i" and "j" in any electric machine can be computed by the equation:

$$L_{ij}(\theta_{rm}) = \mu_0 r l \int_0^{2\pi} g^{-1}(\theta_{rm}) N_i(\theta_{rm}, \phi) N_j(\theta_{rm}, \phi) d\phi \quad (1)$$

The term $g^{-1}(\theta_{rm})$ is termed the inverse gap function which becomes a constant for the uniform airgap machine and is a constant in d-axis under the pole face and approximately zero in the q-axis for

a salient-pole machine. The angle ϕ defines a particular angular position along the stator inner surface while θ_{rm} is the angular position of the rotor with respect to some stator reference. The term $N_i(\theta_{rm}, \phi)$ is called the winding function and represents, in effect, the MMF distribution along the air gap for a unit current in winding i . If this winding is located on the stator, the winding function is only a function of the stator peripheral angle ϕ while if the winding is located on the rotor the winding must be expressed as a function of both ϕ and the mechanical position of the rotor θ_{rm} .

Winding functions for the two equivalent stator windings representing the four and eight pole windings are drawn in Figs. 5(a) and (b). Note that a substantial space harmonic content is present in the winding function plots. Hence, the influence of the space harmonics is appreciable with this machine and its effects on performance will be discussed at a later stage in this paper. Nonetheless, the winding function method gives a very straightforward description of the winding since the overall winding layout is depicted by the winding function and the coupling of the individual coils making up one phase is automatically included.

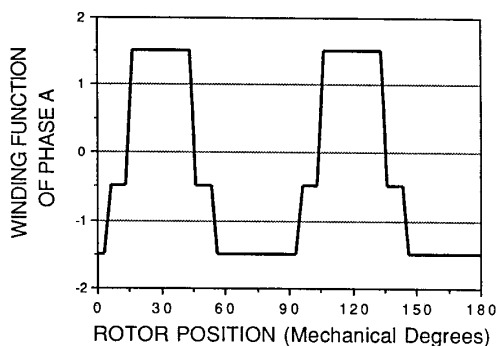

(a)

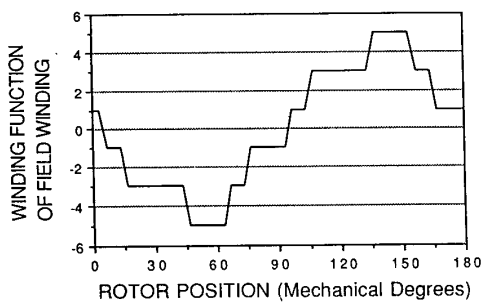

(b)

Fig. 5 Winding Functions for the Two Equivalent Stator Windings Representing the Four and Eight Pole Windings (a) $2p=8$ Pole Winding Function for Phase A, (b) $2q=4$ Pole Winding Function for Winding F.

When the rotor is axially laminated, computation of the inductance by means of Eq. 1 is not directly applicable since the gap function of Eq. 1 does not adequately describe the saliency condition imposed on the stator flux. Extension of winding function theory is possible, however, if it is assumed that the reluctance across the interlaminar gap is infinitely large and thus the leakage flux across the interlaminar paths can be neglected. Hence, the pattern of airgap flux depends not only on the stator MMF but also the rotor position.

To take the rotor position into account, an alternative form of the Eq. 1 is written as

$$L_{i,j}(\theta_{rm}) = \frac{\mu_0 r l}{g} \int_0^{2\pi} N_i(\phi) N_j'(\phi, \theta_{rm}) d\phi \quad (2)$$

where $N_j'(\phi, \theta_{rm})$ is termed the effective winding function for winding j including the effects of rotor permeance and rotor position θ_{rm} when the machine is excited by currents in winding j . Compared with Eq. 1, the term $N_j'(\phi, \theta_{rm})$ in Eq. 2 is a composite function which describes the effect of the rotor saliencies on the flux distribution. A detailed derivation of Eq. 2 is given in Appendix A1. Note that with the assumptions imposed, together with the definition of $N_j'(\phi, \theta_{rm})$, the airgap of the DERM becomes a constant in Eq. 2 which simplifies the computation significantly.

The above algorithm for the computation of the inductances can be readily implemented into a small digital computer program. All of the relevant self and mutual inductances of the DERM can then be computed as a function of the rotor position. Figure 6 shows the results of inductance calculations for the DERM. Note that while the stator self and mutual inductances, Fig. 6(a) and 6(b) are nearly constant, dips in the self inductances occur every 30 mechanical degrees (120 electrical degrees for the eight pole stator winding). These dips occur due to the rotor saliency which produces a minimum permeance condition in a given phase every 90 electrical degree rotation of the six pole rotor. Since the three phases of the eight pole stator winding are themselves shifted by 120 electrical degrees, the dip occurs at precisely the same point in each of the three self inductances. The same phenomenon occurs for the three eight, four pole winding mutual inductances, see Fig. 6(c). The dips also exist in the four pole winding self inductance and is periodic with a period 30 mechanical degrees (60 electrical degrees of the four pole stator winding), Fig. 6(d).

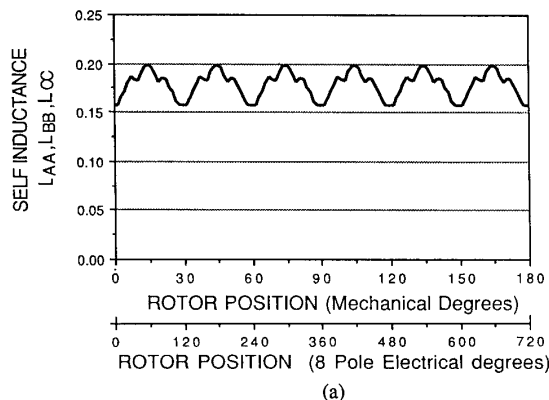

(a)

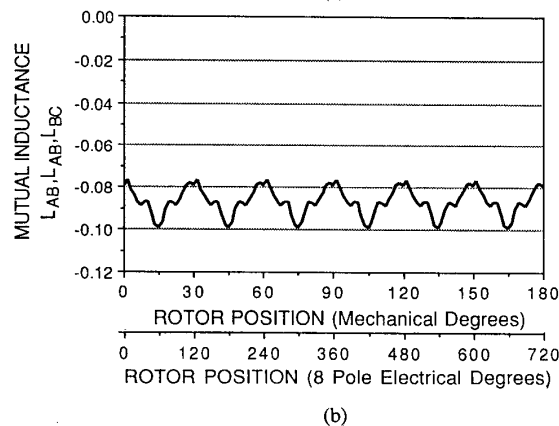

(b)

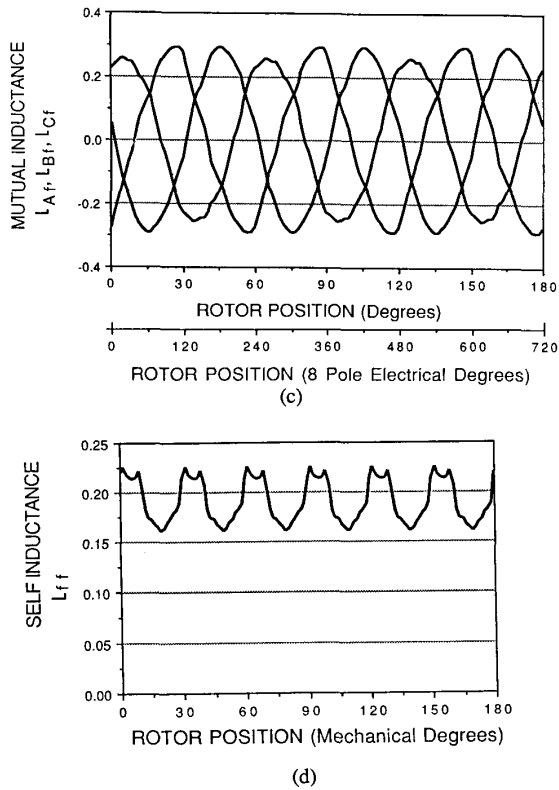

Fig. 6 Inductances of DERM Machine (a) 2p Pole Self Inductance $L_{aa}=L_{bb}=L_{cc}$, (b) 2p Pole Mutual Inductance $L_{ab}=L_{bc}=L_{ca}$, (c) 2p,2q Pole Mutual Inductances L_{af}, L_{bf}, L_{cf} , (d) 2q Pole Self Inductance L_{ff} .

By examining the computed results of the self and mutual inductances of the DERM machine, the following conclusions are reached immediately:

- 1). The inductances of the 3 phase, 8 pole windings are nearly constant for all rotor positions suggesting that the DERM is nearly equivalent to a round rotor synchronous machine. The relatively constant value of the inductance implies that these inductance values are not associated with the mechanical rotation of the rotor. Thus, they do not play a role in the process of the electromechanical energy conversion;
- 2). The inductances for the 2q=4 pole winding displays a similar constant nature as that of 2p=8 pole windings. If the machine were equipped with only one of these two sets of windings, or without mutual coupling between these two windings, no electromagnentic energy conversion could be accomplished by the machine;
- 3). The mutual inductances between the 8-pole and 4-pole windings vary sinusoidally with a period of 60 mechanical degrees. The dependance of the mutual inductance on position indicates that when the single phase four-pole winding is excited, a three-phase symmetric sinusoidal speed voltage will be induced in eight-pole winding when the rotor rotates. These induced speed voltages are a necessary condition in the process of electromagnetic energy conversion.

It is interesting to note that the mutual inductance between the two windings with different pole-pitch varies as a function of rotor position with a period which is different from the pole-pitch of either group of stator windings. It is also instructive to compare the DERM with a conventional round-rotor synchronous machine. Although the flux of the DERM is not distributed sinusoidally with rotor position and the number of poles of the stator and rotor is not equal, the profile of the terminal winding inductances for the DERM are identical to that of a 12-pole round rotor synchronous machine. Therefore, the single phase winding behaves as if it were a field winding located on the rotor, and the three phase winding behaves as the armature winding of a 12 pole machine.

Transformation of Inductances into d-q-n Synchronous Reference Frame

The theory of reference frame transformations can now be extended and applied to the analysis of the DERM machine in the same manner as the classical analysis for a conventional synchronous machine. By inspection, the circuit differential equations describing the machine are simply,

$$\underline{v}_{abc} = r_s \underline{i}_{abc} + \frac{d\lambda_{abc}}{dt} \quad (3)$$

$$v_f = r_f i_f + \frac{d\lambda_f}{dt} \quad (4)$$

where $\underline{v}_{abc} = \begin{pmatrix} v_a \\ v_b \\ v_c \end{pmatrix}$, $\underline{i}_{abc} = \begin{pmatrix} i_a \\ i_b \\ i_c \end{pmatrix}$,

$$\lambda_{abc} = \underline{L}_{abc} \underline{i}_{abc} + \underline{L}_{abcf} i_f$$

$$\lambda_f = \underline{L}_{fabc} \underline{i}_{abc} + L_{ff} i_f$$

with $\underline{L}_{abc} = \begin{pmatrix} L_{aa} & L_{ab} & L_{ac} \\ L_{ba} & L_{bb} & L_{bc} \\ L_{ca} & L_{cb} & L_{cc} \end{pmatrix}$, $\underline{L}_{abcf} = \begin{pmatrix} L_{af} \\ L_{bf} \\ L_{cf} \end{pmatrix}$,

and $\underline{L}_{abcf} = \underline{L}_{fabc}^T$. The quantity "T" denotes the transpose.

Additional equations for the torque and speed are

$$T_e = [\underline{i}_{abc}]^T \frac{\partial [\underline{L}_{abcf}((p+q)\theta_{rm})]}{\partial \theta_{rm}} i_f \quad (5)$$

$$J \frac{d\omega_{rm}}{dt} = T_e - T_l \quad (6)$$

where J denotes the rotor inertia and T_l is the load torque.

To predict the dynamic performance of the machine, Eqs. 3-6 containing time-varying parameters need to be solved simultaneously. On the other hand, the equations can be transformed to a $d-q$ rotating axis in the same manner as a synchronous machine. In particular, it is desirable to choose a transformation $\underline{T}(\theta)$ such that the parameters and variables associated with the eight-pole windings become constants. Since the four pole machine acts as the field winding, the equations describing the four pole winding need not undergo a transformation.

Recall that in a conventional $d-q-n$ transformation, the matrix transformation takes the form

$$\underline{T}(\theta) = \frac{2}{3} \begin{pmatrix} \sin(\theta) & \sin(\theta - \frac{2\pi}{3}) & \sin(\theta + \frac{2\pi}{3}) \\ \cos(\theta) & \cos(\theta - \frac{2\pi}{3}) & \cos(\theta + \frac{2\pi}{3}) \\ \frac{1}{\sqrt{2}} & \frac{1}{\sqrt{2}} & \frac{1}{\sqrt{2}} \end{pmatrix} \quad (7)$$

where θ is defined as the angular displacement from the original coordinates to the new coordinates. If the rotor is rotating with respect to the original coordinates at the electrical angular speed ω_r ,

then a transformation to the rotor reference frame implies $\theta = \int \omega_r dt$

where $\omega_r = p\omega_{rm}$ in which p is the number of pole pairs and ω_{rm} is the actual mechanical speed. In the case of the DERM machine the number of equivalent poles is $2(p + q) = 4 + 8 = 12$. However, in terms of an 8 pole winding, the rotor appears to rotate at a speed corresponding to 8 poles. Hence, the value of θ should be selected such that $\omega_r = p\omega_{rm}$.

When the transformation is applied to Eqs. 3-6 the ultimate form of the equations under the extended $d-q-n$ transformation are of the standard form,

$$v_{dqns} = r_s i_{dqns} + \frac{d\lambda_{dqns}}{dt} + \omega_r \times \lambda_{dqns} \quad (8)$$

$$v_f = r_f i_f + \frac{d\lambda_f}{dt} \quad (9)$$

where
$$v_{dqns} = \begin{pmatrix} v_{ds} \\ v_{qs} \\ v_{ns} \end{pmatrix}, \quad i_{dqns} = \begin{pmatrix} i_{ds} \\ i_{qs} \\ i_{ns} \end{pmatrix},$$

$$\lambda_{dqns} = \begin{pmatrix} \lambda_{ds} \\ \lambda_{qs} \\ \lambda_{ns} \end{pmatrix}, \quad \omega_r = \begin{pmatrix} \omega_r \\ 0 \\ 0 \end{pmatrix},$$

and "x" represents the vector cross product of ω_r and λ_{dqns} . Also, the flux linkages are related to the currents, in matrix form,

$$\lambda_{dqns} = L_{dqns} i_{dqns} + L_{dqnf} i_f$$

$$\lambda_f = L_{fdqn} i_{dqns} + L_{ff} i_f$$

wherein
$$L_{dqns} = T(p\theta_{rm}) L_{abc} T(p\theta_{rm})^{-1} = \begin{pmatrix} L_{ds} & 0 & 0 \\ 0 & L_{qs} & 0 \\ 0 & 0 & L_{ls} \end{pmatrix}$$

$$L_{dqnf} = T(p\theta_{rm}) L_{abcf} T(p\theta_{rm}) = \begin{pmatrix} L_{df} \\ L_{gf} \\ 0 \end{pmatrix},$$

and $L_{fdqn} = L_{dqnf}^T$. It is important to note that for diagonalization of the matrix to occur, the inductance matrix L_{abcf} should be expressed as a function of $p\theta_{rm}$.

The torque equation of the DERM under the transformation becomes

$$T_e = \frac{3}{2} (p+q) (\lambda_{ds} i_{qs} - \lambda_{qs} i_{ds}) \quad (10)$$

where $p+q = 6$.

Based on the new equations in the transformed coordinates the equivalent circuit shown in Figure 7 is suggested. It is interesting to

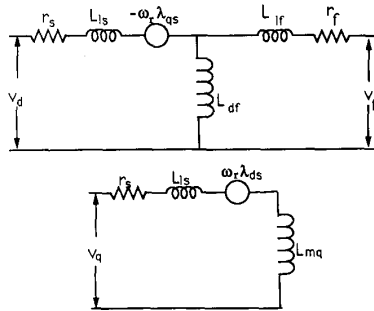
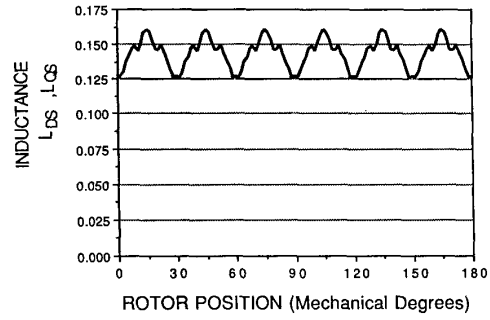
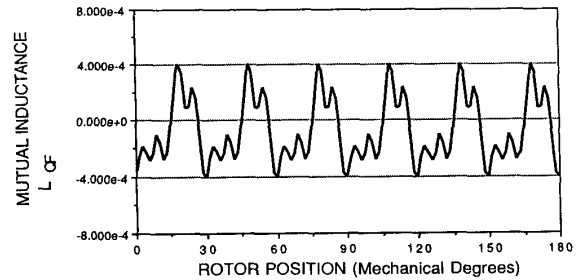
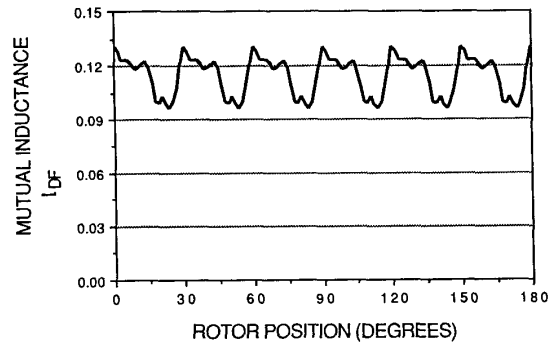

Fig. 7 Equivalent Circuit of Doubly Excited Reluctance Machine.

observe that the doubly excited reluctance machine is equivalent to a round rotor synchronous machine without an amortisseur cage. Figure 8 shows plots of the inductances of the machine in the synchronous reference frame. Note that the inductances have the same pulsation of 30 mechanical degree periodicity as the actual phase inductances.



(a)



(c)

Fig. 8 Inductance of DERM Machine in d,q Components (a) 2p Pole Direct and Quadrature Axis Inductances $L_{ds}=L_{qs}$, (b) 2p,2q Pole Mutual Inductance L_{df} , (c) 2p,2q Pole Mutual Inductance L_{qf} .

Comparison of Computed and Tested Results

In order to validate the computer model which has been developed, tests were made on a prototype 15 HP machine. This machine is rated at 230V. Figure 10 shows the measured three phase currents for the 2p pole winding for the case where the

machine is connected to the supply at no load. This condition is shown as it provides the greatest distortion in the current waveform. The field current has been adjusted to cause an open circuit voltage of 150 V. A substantial dissymmetry can be observed caused by the 30 degree pulsation in the self and mutual inductances. In Figure 10 the machine was simulated by the equivalent circuit of Fig. 7. In particular, the ripples in the inductances shown in Figs. 7 and 8 have been neglected. In this case, the solution is the same as a round rotor synchronous machine with sinusoidally distributed windings. Figure 10 shows the results of a computer simulation using Eqs. 8-10 and the average values of the inductances of Figs. 6 and 8. It can be observed that although the fundamental components of the currents are reasonably well predicted the harmonics are totally absent. This is, of course, to be expected since the conventional d-q model is not capable of predicting the effects of higher order space harmonics.

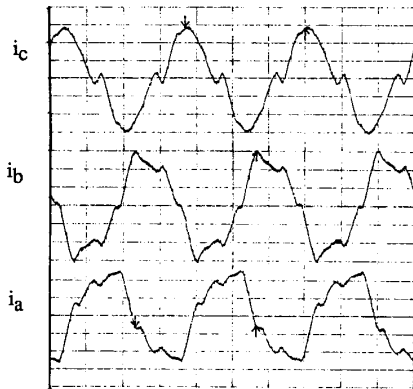

Fig. 9 Test Results from 15 HP Doubly Excited Reluctance Motor Operating with Lagging Power Factor at No-Load with 1.0 A Field Current. Supply Voltage - 115 V, Frequency 60 Hz, Field Current $I_f = 1.0A$. Scale: 1.0 A/div.

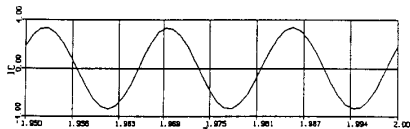

Fig. 10 Simulation Results for the Case of Fig. 9 Using Only the Average Values of the Inductances L_{ds} , L_{qs} , L_{df} , L_{qf} and L_{ff} (See Figs. 6 and 8).

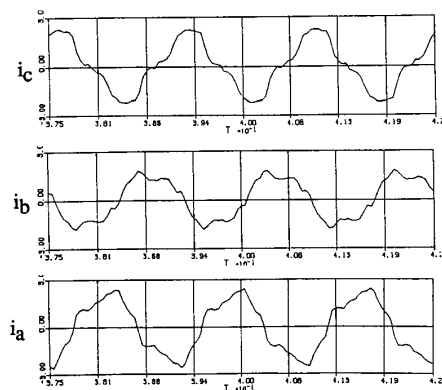

Fig. 11 Simulation Results for the Case of Fig. 9 Incorporating the Exact Values of Inductances L_{ds} , L_{qs} , L_{df} , L_{qf} and L_{ff} as Calculated by Means of Winding Functions.

In Fig. 11 the equations have again been simulated, this time including the harmonics present in the d-q inductance waveforms. In this case, harmonics occur in the simulated waveform which correspond quite accurately to the measured results. The relatively minor discrepancies which remain can be attributed to the approximations used to obtain the winding functions of Eq. 2.

Conclusion

By application of winding functions as well as transformation theory, a transient model has been developed for the doubly excited reluctance machine. The computer simulation of the DERM based on the transient model shows that by means of generalized transformation theory, a concise equivalent circuit with constant parameters can be obtained for DERM machine in spite of the fact that the machine is characterized by an air gap flux of pulsating amplitude. The transient modeling and simulation of DERM has also generally verified that AC machines with non-sinusoidal air gap flux can be studied with conventional transformation theory (Park's Transformation) resulting in a similar approach as is obtained in the study of conventional AC machines with the conventional d-q-n transformation.

The extension of this theory to the induction machine version of this machine, Fig. 1, is straightforward and will be reported in a future paper when a suitable test machine becomes available.

Acknowledgments

The authors wish to thank the personell at the Oak Ridge National Laboratories, Oak Ridge Tennessee in particular T.L. Hudson for use of the 15 HP doubly excited reluctance motor. They are also indebted to the industrial sponsors of WEMPEC (Wisconsin Electric Machines and Power Electronics Consortium) for funds and facilities provided.

References

- [1] L.J. Hunt, "The Cascade Induction Motor," J. IEE Vol 52, pp. 406-426, 1914.
- [2] F. Creedy, "Some Developments in Multi-Speed Cascade Induction Motors", J. IEE, vol 59, pp. 551-552, 1921.
- [3] A. Kusko and C.B. Somuah, "Speed Control of a Single-Frame Cascade Induction Motor with Slip-Power Pump Back", IEEE Trans. on Industry Applications, vol IA-14, March/April 1978, pp. 97-105.
- [4] A.R.W. Broadway and G. Thomas, "Single-Unit PAM Induction Frequency Convertors," Proc IEE, vol 114, 1967, pp. 958-964.
- [5] A.R.W. Broadway, L. Burbridge, "Self-Cascaded Machine: a Low-Speed Motor or High-Frequency Brushless Alternator", Proc. IEE, Vol. 117, July 1970, pp 1277-1290.
- [6] A.R.W. Broadway, "Cageless Induction Motor", Proc. IEE, vol 118, pp. 1593-1600, 1971.
- [7] A.R.W. Broadway, "Brushless Stator-Controlled Synchronous-Induction Machine", Proc. IEE, vol. 120, August 1973, pp. 860-866.
- [8] A.R.W. Broadway and G. Thomas, "Brushless Cascade Alternator", Proc. IEE, vol 121, pp. 1529-1535, 1974.
- [9] C.J. Heyne and A.M. El-Antaby, "Reluctance and Doubly-Excited Reluctance Motors", Final Report, Oak Ridge National Laboratories, Report ORNL/SUB/81-95013/1, 123 pp.
- [10] R.L. Russell and K.H. Norsworthy, "A Stator-Fed Half-Speed Synchronous Motor", Proc. IEE, vol 104A, 1957, pp. 77-87.
- [11] N.L. Schmitz and D.W. Novotny, "Introductory Electromechanics", (book) Ronald Press, New York, 1965.
- [12] T.A. Lipo, "Analysis of Synchronous Machines", University of Wisconsin, 1987, 297 pp.

Appendix 1

Inductance of an Axially Laminated Structure

Consider initially the simplified winding arrangement of Fig. A1-1 in which the stator is equipped with only two concentrated windings A and B having N_a and N_b turns and pole pitches τ_a and τ_b in mechanical degrees respectively. While the derivation is true for either case, it will be assumed that $\tau_a < \tau_b$.

Assume first that the rotor is isotropic. The flux linking winding B due to a current i_A in winding A would then be:

$$\Phi_b = \frac{\mu_0 r l}{g} \left[\int_0^{\tau_a} \left(\frac{2\pi - \tau_a}{2\pi} \right) N_a i_A d\phi - \int_{\tau_a}^{\tau_b} \left(\frac{\tau_a}{2\pi} \right) N_a i_A d\phi \right] \quad (A1.1)$$

We can express this equation in a simpler form if we define an MMF function $F_a(\phi)$ and a turns function locating the position of winding B such that

$$\begin{aligned} F_a(\phi) &= \left(\frac{2\pi - \tau_a}{2\pi} \right) N_a i_A & \text{for } 0 < \phi < \tau_a \\ F_a(\phi) &= - \left(\frac{\tau_a}{2\pi} \right) N_a i_A & \text{for } \tau_a < \phi < 2\pi \\ n_b(\phi) &= 0 & \text{for } \phi < \alpha \text{ and } \phi > \tau_b + \alpha \\ n_b(\phi) &= N_b & \text{for } \alpha \leq \phi \leq \tau_b + \alpha \end{aligned}$$

Equation 1 can now be written

$$\Phi_b = \frac{\mu_0 r l}{g} \int_0^{2\pi} n_b(\phi) F_a(\phi) d\phi \quad (A1.2)$$

Consider now the axially laminated rotor of Fig. A1-1 with pole pitch τ_r in which the "q" axis rotor is displaced from winding a by a mechanical angle θ_{rm} . In this case, ideally, no flux is produced in the air gap over the region $0 \leq \phi \leq 2\theta_{rm}$ and at similar points along the air gap due to the laminated structure. Equation A1.2 could be continued to be used if a permeance function is defined such that

$$\begin{aligned} \mathcal{P}_a(\phi, \theta_{rm}) &= 0 & \text{for } 0 \leq \phi \leq 2\theta_{rm}; \tau_r \leq \phi \leq 2\theta_{rm} + \tau_r; \\ & & \text{and } \phi > 2\tau_r \end{aligned}$$

and $\mathcal{P}_a(\phi, \theta_{rm}) = 1$ for $2\theta_{rm} \leq \phi \leq \tau_r$; $2\theta_{rm} + \tau_r \leq \phi \leq 2\tau_r$ and zero elsewhere. Equation A1.2 then becomes

$$\Phi_b = \frac{\mu_0 r l}{g} \int_0^{2\pi} n_b(\phi) \mathcal{P}_a(\phi, \theta_{rm}) F_a(\phi) d\phi \quad (A1.3)$$

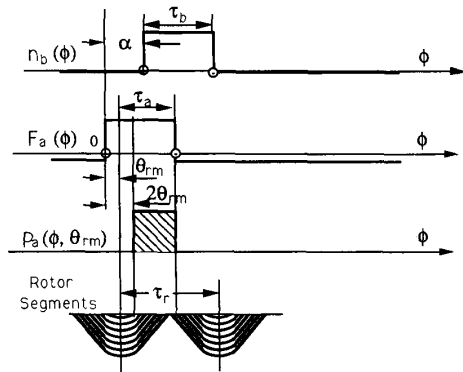

Fig. A1-1 Illustration of for Derivantion Showing (from the top) Turns Function of Winding B - $n_b(\phi)$, MMF Function of Winding A - F_a , Permeance Function Describing Effect of Axial Laminations.

Note that \mathcal{P}_a is unitless since the actual permeance of the air gap is represented by the coefficient in front of the integral of Eq. A1.3.

The flux linking winding B due to all such coils excited by current i_A is obtained in an identical manner. If phase A is comprised of C_A coils then the total flux linking coil B is

$$\Phi_b = \frac{\mu_0 r l}{g} \int_0^{2\pi} n_b(\phi) \sum_{n=1}^{C_A} \mathcal{P}_{an}(\phi, \theta_{rm}) F_{an}(\phi) d\phi \quad (A1.4)$$

the summation inside the integral can be considered as the equivalent MMF resulting from the saliency imposed by the axially laminated rotor. It is useful to define the equivalent MMF function,

$$F'_A(\phi, \theta_r) = \sum_{n=1}^{C_A} \mathcal{P}_{an}(\phi, \theta_{rm}) F_{an}(\phi) d\phi \quad (A1.5)$$

Equation A1.5 becomes simply

$$\Phi_b = \frac{\mu_0 r l}{g} \int_0^{2\pi} n_b(\phi) F'_A(\phi, \theta_{rm}) d\phi \quad (A1.6)$$

As defined by Eq. A1.5, the modified MMF can be used to establish the air gap MMF and thus the flux density distribution for any winding distribution and number of poles. For purpose of illustration, Fig. 4 depicts the air gap MMF for the 8 pole winding of the DERM assuming perfect sinusoidal distribution of the turns.

If coil B is but one of several coils making up winding B it is possible to continue this process for all such coils. The result is

$$\sum_{n=1}^{C_B} \Phi_{bn} = \lambda_B = \frac{\mu_0 r l}{g} \int_0^{2\pi} \sum_{n=1}^{C_B} n_{bn}(\phi) F'_A(\phi, \theta_{rm}) d\phi \quad (A1.7)$$

The summation inside the integral can be termed the turns function for winding B, that is

$$n_B(\phi) = \sum_{n=1}^{C_B} n_{bn}(\phi)$$

so that Eq. A1.6 reduces to

$$\lambda_B = \frac{\mu_0 r l}{g} \int_0^{2\pi} n_B(\phi) F'_A(\phi, \theta_{rm}) d\phi \quad (A1.8)$$

In general, the turns function $n_B(\phi)$ has both an average component and harmonic components related to the pole pitch. If we let $\langle n_B \rangle$ denote the average component, then

$$\langle n_B \rangle = \frac{1}{2\pi} \int_0^{2\pi} n_B(\phi) d\phi \quad (A1.9)$$

and define the winding function for winding B as

$$N_B(\phi) = n_B(\phi) - \langle n_B \rangle$$

Eq. A1.8 becomes

$$\lambda_B = \frac{\mu_0 r l}{g} \left[\int_0^{2\pi} N_B(\phi) F'_A(\phi, \theta_{rm}) d\phi + \int_0^{2\pi} \langle n_B \rangle F'_A(\phi, \theta_{rm}) d\phi \right] \quad (A1.10)$$

By Gauss' Law the MMF cannot have an average value since this would correspond to a net flow of flux across the gap. Hence, the second term of Eq. A1.8 is identically zero. Finally if we define a second winding function for winding A such that

$$N'_A(\phi, \theta_{rm}) = \frac{F'_A(\phi, \theta_{rm})}{i_A}$$

then the mutual inductance between winding A and winding B is simply

$$L_{AB} = L_{BA} = \frac{\lambda_B}{i_A} = \frac{\mu_0 r l}{g} \int_0^{2\pi} N_B(\phi) N'_A(\phi, \theta_{rm}) d\phi \quad (A1.11)$$

Longya Xu was born in Hunan province, the PR of China. He graduated from Shangtan Institute of Electrical Engineering in 1970 with Diploma. He received B.E.E. from Hunan University in China and M.S. from the University of Wisconsin-Madison in U.S.A., in 1982 and 1986, respectively. He is currently a Ph.D Student in the Department of ECE, University of Wisconsin-Madison.

From 1971-1978 he participated in the 120 kw synchronous machine design, manufacturing and testing in China. From 1982-1984, he worked as researcher for linear electric machine, in the Institute of Electrical Engineering Sinica Academia of China. Since 1984, he is a teaching and researching assistance in the University Wisconsin-Madison. His area of interests includes power electronics and converter optimized electrical machine design, modeling and simulation.

Feng Liang was born in Nanning, China in 1956. He received his B.S. degree in Electrical Engineering from the South China Institute of Technology in 1982 and the M.S. degree from Hunan University in 1986. From 1986 to 1988 he was a lecturer of South China University of Technology and published two papers on the application of the Boundary Element Method in the calculation of magnetic fields in electrical machines. He currently is a Ph.D. student of the Department of Electrical and Computer Engineering, University of Wisconsin-Madison where he is involved in AC machine drives and the modelling and simulation of electrical machines.

Thomas A. Lipo (F'87) is a native of Milwaukee, Wisconsin. He received his B.E.E. and M.S.E.E. degrees from Marquette University, Milwaukee, WI in 1962 and 1964 respectively. He obtained the Ph.D. degree in electrical engineering from the University of Wisconsin in 1968. Upon graduation he was a National Research Council postdoctoral fellow at the University of Manchester Institute of Science and Technology, Manchester, England during the period 1968-69. From 1969 to 1979 he was an Electrical Engineer in the Power Electronics Laboratory of Corporate Research and Development of the General Electric Company, Schenectady NY. He became Professor of Electrical Engineering at Purdue University in 1979 and in 1981 he joined the University of Wisconsin in the same capacity.

Dr. Lipo has maintained a deep research interest in power electronics and ac drives for over 25 years. He has received eleven IEEE prize paper awards for his work including co-recipient of the Best Paper Award in the IEEE Industry Applications Society Transactions for the year 1984. In 1986 he received the Outstanding Achievement Award from the IEEE Industry Applications Society for his contributions to the field of ac drives.